

NOTE: 3/4" CHAMFER TYPICAL ON EACH EDGE OF TOP, SIDES AND BOTTOM

PLAN VIEW

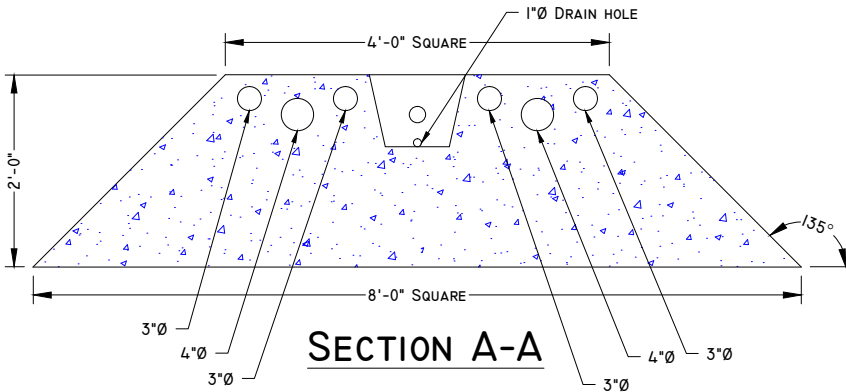

SECTION A-A

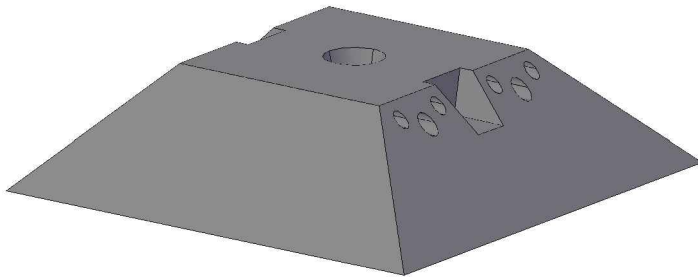

CONCEPTUAL VIEW - NTS

HITCH ROD POCKET DETAIL

SCALE: 1 1/2" = 1'-0"

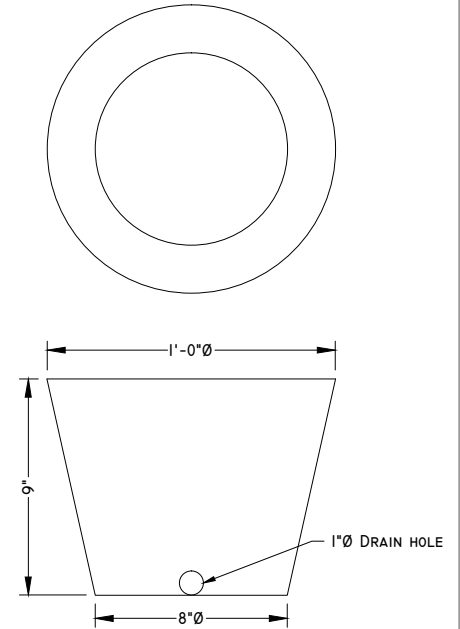

SIDE POCKET DETAIL

SCALE: 1 1/2" = 1'-0"

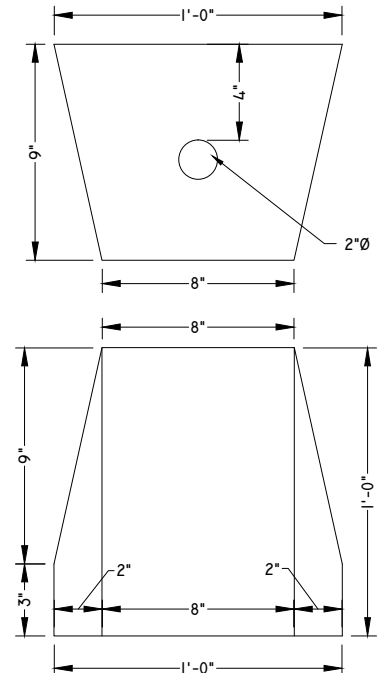

Manufacturing Notes

- 1.1. CONCRETE COMPRESSIVE STRENGTH: 5000PSI
- 1.2. AIR ENTRAINMENT: 4-6%
- 1.3. GRADE 60 REINFORCEMENT
- 1.4. STRUCTURAL FIBER REINFORCEMENT

Physical Specifications:

ACTUAL DRY WEIGHT: 10,755 LBS
 BUOANCY WEIGHT: 6,280 LBS